

# Hydrogen technologies as a medium to increase the penetration of RES in non-interconnected power systems. Milos case study

E. Zoulias, E. Stamatakis, G. Tzamalidis, O. Parissi

Centre for Renewable Energy Sources and Saving, Department of RES and Hydrogen Technologies, 19<sup>th</sup> Marathonos Av., 190 09, Pikermi, Athens, Greece

**Abstract** - The aim of STORIES project, which started on the 1<sup>st</sup> of November 2007 and it is co-financed by the Intelligent Energy - Europe programme, is to make concrete suggestions for changes in policies and regulations covering RES installations on island grids so as to promote energy storage solutions in order to increase RES penetration. The main objective of the current work is the evaluation of hydrogen technologies as a medium for increasing the penetration of RES in the Greek island of Milos. Two simulations have been performed. In the first run we have simulated the existing power system of the Milos island, where 86.6 % of the electric demand is covered by fossil fuels and 13.4 % by Renewables. In the second simulation the increase of RES penetration in combination with hydrogen technologies has been examined. Here, hydrogen has been used as a storage medium of the RES excess electricity. The feasibility study for the hydrogen technologies is based mainly on technical and economic issues. For both power systems we compare the cost of the energy produced and the overall consumption of fossil fuels. Furthermore, the increase on the renewable fraction (portion of the system's total energy production originating from renewable power sources) in combination with the reduction in emissions produced are also examined. All simulations, optimization of the component sizes and sensitivity analysis have been performed using the hybrid optimization model for electric renewables (HOMER) simulation tool.

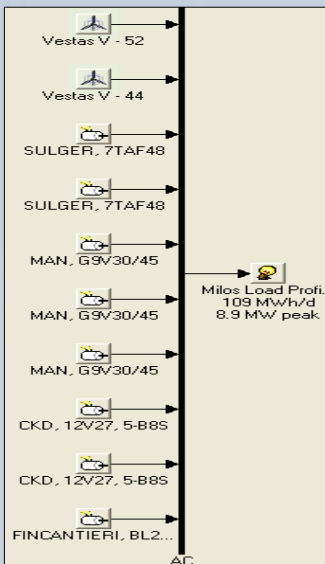

Milos Island: Existing Power System

## Work description

- In the existing power system of Milos island, the electrical load is provided by 8 thermal generators (diesel, heavy oil) of 11,25 MW installed power and by 3 wind turbines of 2,05 MW installed power.
- In the proposed power system the island's electrical load is provided by 5 thermal generators, 30 wind turbines (25 MW installed power) and 1 PEM Fuel Cell (1 MW installed power). There are also 1 alkaline electrolyser and 1 hydrogen tank (3.000 kg).

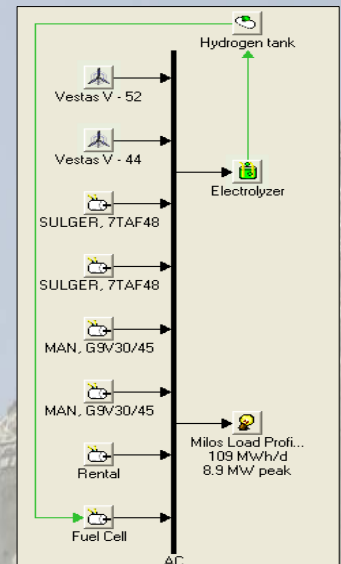

Milos Island: Proposed Power System

## Results

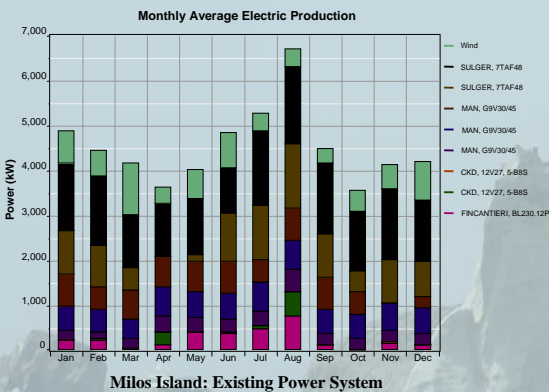

Milos Island: Existing Power System

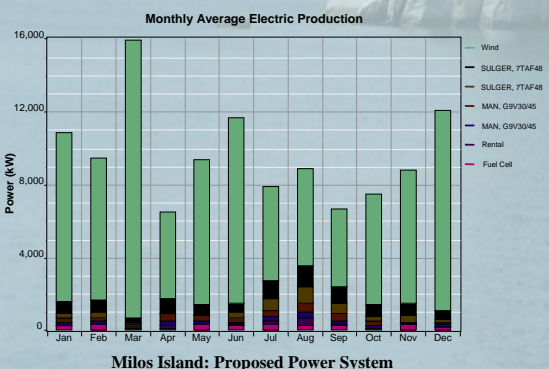

Milos Island: Proposed Power System

## Conclusions

Pollutant	Emissions (kg/yr)	
	Existing Power System	Proposed Power System
CO <sub>2</sub>	26.928.306	10.507.571
CO	57.356	23.063
Unburned H/C	6.353	2.555
Particulate matter	4.324	1.739
SO <sub>2</sub>	524.180	211.079
NO <sub>x</sub>	511.791	205.789

The introduction of hydrogen as energy storage method in Milos results in:

- increase in the power generation cost of the island (ca. 43%)
- huge increase on RE penetration on the island (from 13% to 85%)
- significant reduction in fossil fuels consumption (ca. over 50%)
- significant reduction in emissions produced (especially in CO<sub>2</sub>, ca. over 50% for all pollutants)
- further reduction on the cost of hydrogen energy equipment and the introduction of external costs makes the hydrogen-based system economically competitive to the existing one

## Acknowledgement

The authors would like to thank IEE for partly funding the STORIES project. For more info please visit [www.storiesproject.eu](http://www.storiesproject.eu)